



Tubing Selection

Proper selection, handling, and installation of tubing, when combined with proper selection of XINVAL tube fittings, are essential for reliable tubing systems.

The following variables should be considered when ordering tubing for use with XINVAL tube fittings:

- ⦿ Surface finish
- ⦿ Material
- ⦿ Hardness
- ⦿ Wall thickness

Tubing Surface Finish

Many ASTM specifications cover the above requirements, but they often are not very detailed on surface finish. For example, ASTM A450, a general tubing specification, it is specified as below:

12. Straightness and Finish

12.1 Finished tubes shall be reasonably straight and have smooth ends free of burrs. They shall have a workmanlike finish. Surface imperfections (Note) may be removed by grinding, provided that a smooth curved surface is maintained, and the wall thickness is not decreased to less than that permitted by this or the product specification. The outside diameter at the point of grinding may be reduced by the amount so removed.

Note: An imperfection is any discontinuity or irregularity found in the tube.

Material

Our suggested ordering instructions for each type of tubing are shown under the respective tables.

Hardness

The key to selecting proper tubing for use with metal XINVAL tube fittings is that the tubing must be softer than the fitting material. XINVAL tube fittings are designed to work properly with the tubing that is suggested in the ordering instructions.

Wall Thickness

The accompanying tables show working pressure of tubing in a wide range of wall thicknesses. Allowable working pressure are calculated from S values as specified by ASME B31.3, Process Piping. XINVAL tube fittings have been repeatedly tested in both the minimum and maximum wall thicknesses shown. XINVAL tube fittings are not recommended for tube wall thicknesses outside the ranges shown in the accompanying tables for each size.

Tubing Handling

It is important to properly handle the tubing in order to reduce the scratches and protect the surface finish.

- ⦿ Tubing should never be dragged out of a tubing rack or across a rough surface.
- ⦿ Tube cutters or hacksaws should be sharp. Do not take deep cuts with each turn of the cutter or stroke of the saw.
- ⦿ Remove burrs on the tube end which will be helpful for the tubing go through the ferrules without damaging the ferrule sealing edge.

Gas Service

Gases(air, hydrogen, helium, nitrogen, etc.) have very small molecules that can escape through even the most minute leak path. Some surface defects on the tubing can provide such a leak path. As tube outside diameter (O.D.) increases, so does the likelihood of a scratch or other surface defect interfering with proper sealing.

The most successful connection for gas service will occur if all installation instructions are carefully followed and the heavier wall thicknesses of tubing on the accompanying tables are selected.

A heavy-wall tube resists ferrule action more than a thin-wall tube, allowing the ferrules to coin out minor surface imperfections and grip the tube more firmly. Within the applicable suggested allowable working pressure table, select a tube wall thickness whose working pressure is outside of the shaded areas.

Tubing Installation

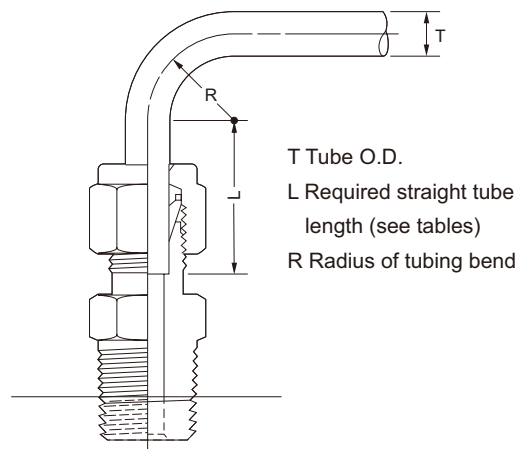

Tubing properly selected and handled, combined with properly installed XINVAL tube fittings, will give you a leaktight system and provide reliable service in a wide variety of applications.

For maximum assurance of reliable performance, use:

- ☉ Properly selected and handled high-quality tubing —such as provided by XINVAL.
- ☉ XINVAL tube fittings assembled in accordance with catalog instructions.

When installing fittings near tube bends, there must be a sufficient straight length of tubing to allow the tube to be bottomed in the XINVAL fitting.

Types of Tubing

Available in TP series. Materials include stainless steel, duplex stainless steel or Nickel-based alloy Enhanced-316/316L, with Ni ,Cr and Mo contents in close approximation to upper values in ASTM standard are,available

- ☉ TP series seamless straight-length tubing pickled or bright annealed external surface mechanically polished

Fractional, in.	
T Tube O.D.	L [Ⓢ]
1/16	1/2
1/8	23/32
3/16	3/4
1/4	13/16
5/16	7/8
3/8	15/16
1/2	1 3/16
5/8	1 1/4
3/4	1 5/16
7/8	1 1/2
1	1 1/2
1 1/4	2
1 1/2	2 13/32
2	3 1/4

Ⓢ Required straight tube length.

Metric, mm	
T Tube O.D.	L [Ⓢ]
3	19
6	21
8	23
10	25
12	31
14	32
15	
16	
18	34
20	
22	
25	40
28	46
30	50
32	54
38	63
50	80

Hydraulic Presetting Tools

A XINVAL hydraulic presetting tool must be used to install XINVAL tube fittings over 1 in. (25 mm). For tube fittings in 1 1/4, 1 1/2, and 2 in. (28, 30, 32, 38, and 50 mm), a presetting tool can be used to preset ferrules onto the tubing tightly. For more information about installation instructions, please contact XINVAL or our authorized distributors.

Suggested Allowable Working Pressure for Tubing

Figures and tables are for reference only. No implication is made that these values can be used for design work. Applicable codes and practices in industry should be considered. ASME Codes are the successor to and replacement of ASA Piping Codes.

- ☉ All pressures are calculated from equations in ASME B31.3, Process Piping. See factors for calculating working pressures in accordance with ASME B31.1, Power Piping.
- ☉ Calculations are based on maximum O.D. and minimum wall thickness, except as noted in individual tables.
Example: 1/2 in. O.D.×0.035 in. wall thickness stainless steel tubing purchased to ASTM A269:
O.D. Tolerance ±0.005 in. / Wall Thickness Tolerance ±10%
Calculations are based on 0.505 in.O.D.×0.0315 in. wall thickness tubing.
- ☉ No allowance is made for corrosion or erosion.

Stainless Steel Tubing

Table 1 — Fractional Seamless Tubing

Allowable working pressures are calculated from an S value of 20 000 psig (137.8 MPa) for ASTM A269 tubing at -20 to 100°F (-28 to 37°C), as listed in ASME B31.3 and ASME B31.1.

For Welded Tubing

For welded and drawn tubing, a derating factor must be applied for weld integrity:

- ☉ For double-welded tubing, multiply working pressure by 0.85.
- ☉ For single-welded tubing, multiply working pressure by 0.80.

Tube O.D. (in.)	Tube Wall Thickness, in.															
	0.010	0.012	0.014	0.016	0.020	0.028	0.035	0.049	0.065	0.083	0.095	0.109	0.120	0.134	0.156	0.188
	Working Pressure, psig															
1/16	5600	6800	8100	9400	12000											
1/8						8500	10900									
3/16						5400	7000	10200								
1/4						4000	5100	7500	10200							
5/16							4000	5800	8000							
3/8							3300	4800	6500							
1/2							2600	3700	5100	6700						
5/8								2900	4000	5200	6000					
3/4								2400	3300	4200	4900	5800				
7/8								2000	2800	3600	4200	4800				
1									2400	3100	3600	4200	4700			
1 1/4										2400	2800	3300	3600	4100	4900	
1 1/2											2300	2700	3000	3400	4000	4900
2												2000	2200	2500	2900	3600

Note: For gas service, select a tube thickness outside of the shaded area.

Suggested Ordering Information

High-quality, fully annealed (Type 304/304L, 316 316L) (seamless or welded and drawn) stainless steel hydraulic tubing, ASTM A269 or A213, or equivalent. Hardness not to exceed 90 HRB or 200 HV. Tubing to be free of scratches, suitable for bending and flaring. O.D. tolerances not to exceed ±0.003 in. for 1/16 in. O.D. tubing.

Note: Certain austenitic stainless tubing has an allowable ovality tolerance double the O.D. tolerance and may not fit into XINVAL precision tube fittings. Dual-certified grades such as 304/304L and 316/316L meet the minimum chemistry and the mechanical properties of both alloy grades.

Table 2—Metric Seamless Tubing

Allowable working pressures are based on equations from ASME B31.3 for EN ISO 1127 tubing (D4, T4 tolerance for 3 to 12 mm; D4, T3 tolerance 14 to 50 mm), using a stress value of 137.8 MPa (20 000 psig) and tensile strength of 516.4 MPa (74 900 psig), as listed in ASME B31.3 and ASME B31.1.

Tube O.D. (mm)	Tube Wall Thickness, mm													
	0.8	1.0	1.2	1.5	1.8	2.0	2.2	2.5	2.8	3.0	3.5	4.0	4.5	5.0
	Working Pressure, bar													
3	670													
6	310	420	540	710										
8		310	390	520										
10		240	300	400	510	580								
12		200	250	330	410	470								
14		160	200	270	340	380	430							
15		150	190	250	310	360	400							
16			170	230	290	330	370	400						
18			150	200	260	290	320	370						
20			140	180	230	260	290	330	380					
22			140	160	200	230	260	300	340					
25					180	200	230	260	290	320				
28						180	200	230	260	280	330			
30						170	180	210	240	260	310			
32						160	170	200	220	240	290	330		
38							140	160	190	200	240	270	310	
50										150	180	210	240	270

Note: For gas service, select a tube thickness outside of the shaded area.

Suggested Ordering Information

High-quality, fully annealed (Type 304/304L, 316/316L) stainless steel tubing, EN ISO 1127 or equivalent. Hardness not to exceed 90 HRB or 200 HV. Tubing to be free of scratches, suitable for bending and flaring. O.D. tolerances not to exceed ±0.076 mm for 3 mm O.D. tubing.

Note: Dual-certified grades such as 304/304L, 316/316L meet the minimum chemistry and the mechanical properties of both alloy grades.

For Welded Tubing

For welded and drawn tubing, a derating factor must be applied for weld integrity:

- ☉ For double-welded tubing, multiply working pressure by 0.85.
- ☉ For single-welded tubing, multiply working pressure by 0.80.

Carbon Steel Tubing

Table 3 — Fractional

Allowable working pressures are calculated from an S value of 15 700 psig (108.2 MPa) for ASTM A179 tubing at -20 to 100 °F (-28 to 37 °C), as listed in ASME B31.3. For working pressure in accordance with ASME B31.1, multiply by 0.85.

Tube O.D. (in.)	Tube Wall Thickness, in.												
	0.028	0.035	0.049	0.065	0.083	0.095	0.109	0.120	0.134	0.148	0.165	0.180	0.220
	Working Pressure, psig												
1/8	8000	10200											
3/16	5100	6600	9600										
1/4	3700	4800	7000	9600									
5/16		3700	5500	7500									
3/8		3100	4500	6200									
1/2		2300	3200	4500	5900								
5/8		1800	2600	3500	4600	5300							
3/4			2100	2900	3700	4300	5100						
7/8			1800	2400	3200	3700	4300						
1			1500	2100	2700	3200	3700	4100					
1 1/4				1600	2100	2500	2900	3200	3600	4000	4600	5000	
1 1/2					1800	2000	2400	2600	2900	3300	3700	4100	5100

Note: For gas service, select a tube thickness outside of the shaded area.

Suggested Ordering Information

High-quality, soft annealed seamless carbon steel hydraulic tubing, ASTM A179 or equivalent. Hardness not to exceed 72 HRB or 130 HV. Tubing to be free of scratches, suitable for bending and flaring.

Table 4 — Metric

Allowable working pressures are based on equations from ASME B31.3 for DIN 2391 tubing, using a stress value of 113 MPa (16 300 psig) and tensile strength of 340 MPa (49 300 psig).

Tube O.D. (mm)	Tube Wall Thickness, mm													
	0.8	1.0	1.2	1.5	1.8	2.0	2.2	2.5	2.8	3.0	3.5	4.0	4.5	
	Working Pressure, bar													
3	630	790												
6	290	370	460	590										
8		270	330	430										
10		210	260	330										
12		170	210	270	330	380	420							
14		150	180	230	280	320	350							
15		140	170	210	260	290	330							
16		130	150	200	240	270	300	350						
18			140	170	210	240	270	310						
20			120	160	190	210	240	270	310					
22			110	140	170	190	210	240	280					
25			100	120	150	170	180	210	240	260				
28						150	160	190	210	230	270			
30						140	150	170	200	210	250			
32						130	140	160	180	200	230	270		
38							120	130	150	160	190	230	260	

Note: For gas service, select a tube thickness outside of the shaded area.

Suggested Ordering Information

High-quality, soft annealed carbon steel tubing, DIN 2391 or equivalent. Hardness not to exceed 72 HRB or 130 HV. Tubing to be free of scratches, suitable for bending and flaring.

Copper Tubing

Allowable working pressures are calculated from an S value of 6000 psig (41.3 MPa) for ASTM B75 (B75M) tubing at -20 to 100 °F (-28 to 37°C), as listed in ASME B31.3 and ASME B31.1.

Table 5 — Fractional

Tube O.D. (in.)	Tube Wall Thickness, in.									
	0.028	0.030	0.035	0.049	0.065	0.083	0.095	0.109	0.120	0.134
	Working Pressure, psig									
1/8	2700	3000	3600							
3/16	1800	1900	2300	3400						
1/4	1300	1400	1600	2500	3500					
5/16			1300	1900	2700					
3/8			1000	1600	2200					
1/2			800	1100	1600	2100				
5/8				900	1200	1600	1900			
3/4				700	1000	1300	1500	1800		
7/8				600	800	1100	1300	1500		
1				500	700	900	1100	1300	1500	
1 1/8					600	800	1000	1100	1300	1400

Note: For gas service, select a tube thickness outside of the shaded area.

Table 6 — Metric

Tube O.D. (mm)	Tube Wall Thickness, mm									
	0.8	1.0	1.2	1.5	1.8	2.0	2.2	2.5	2.8	3.0
	Working Pressure, bar									
6	110	140	170	220						
8		100	120	160						
10		80	100	130						
12		60	80	100	130	140				
14		50	60	90	110	120	130			
15			60	80	100	110	120			
16				70	90	100	110	120		
18				60	80	90	100	110		
20				60	70	80	90	100	110	
22				50	60	70	80	90	100	
25				40	50	60	70	80	90	100
28					40	50	60	70	80	90

Note: For gas service, select a tube thickness outside of the shaded area.

Suggested Ordering Information

High-quality, soft annealed seamless copper tubing, ASTM B75 (B75M) or equivalent. Also soft annealed (Temper O) copper water tube, type K or type L to ASTM B88 .

Alloy 400 Tubing

Allowable working pressures are calculated from an S value of 18 700 psig (128.9 MPa) for ASTM B165 tubing at -20 to 100 °F (-28 to 37 °C), as listed in ASME B31.3 and ASME B31.1.

Table 7 — Fractional

Tube O.D. (in.)	Tube Wall Thickness, in.							
	0.028	0.035	0.049	0.065	0.083	0.095	0.109	0.120
	Working Pressure, psig							
1/8	7900	10 100						
1/4	3700	4 800	7000	9500				
5/16		3 700	5400	7300				
3/8		3 100	4400	6100				
1/2		2 300	3200	4400				
3/4			2200	3000	4000	4600		
1				2200	2900	3400	3900	4300

Note: For gas service, select a tube thickness outside of the shaded area.

Table 8 — Metric

Tube O.D. (mm)	Tube Wall Thickness, mm									
	0.8	1.0	1.2	1.5	1.8	2.0	2.2	2.5	2.8	3.0
	Working Pressure, bar									
6	310	390	490	620						
8		290	350	450						
10		220	280	350						
12		180	230	290						
14		160	190	240	270					
18			150	200	240	270	300			
20				180	210	240	270	290		
25					170	190	210	240	270	290

Note: For gas service, select a tube thickness outside of the shaded area.

Suggested Ordering Information

High-quality, fully annealed seamless alloy 400 hydraulic tubing, ASTM B165 or equivalent. Hardness not to exceed 75 HRB or 137 HV. Tubing to be free of scratches, suitable for bending and flaring. O.D. tolerances not to exceed ±0.005 in (±0.13 mm).

Alloy C-276 Tubing

Allowable working pressures are based on equations from ASME B31.3 and ASME B31.1 for a maximum S value of 20 000 psig (137.8 MPa).

Table 9 — Fractional

Tube O.D. (in.)	Tube Wall Thickness, in.			
	0.028	0.035	0.049	0.065
	Working Pressure, psig			
1/4	4000	5100	7500	1 0200
5/16		4000	5800	7 800
3/8		3300	4800	6 500
1/2		2600	3700	5 100

Note: For gas service, select a tube thickness outside of the shaded area.

Suggested Ordering Information

High-quality, fully annealed alloy C-276 tubing, ASTM B622 or equivalent. Hardness not to exceed 100 HRB or 248 HV. Tubing to be free of scratches, suitable for bending and flaring. O.D. tolerances not to exceed ±0.005 in (±0.13 mm).

Alloy 20 Tubing

Allowable working pressures are based on equations from ASME B31.3 and ASME B31.1 for a maximum S value of 20 000 psig (137.8 MPa).

Table 11 — Fractional

Tube O.D. (in.)	Tube Wall Thickness, in.			
	0.028	0.035	0.049	0.065
	Working Pressure, psig			
1/4	4000	5100	7500	1 0200
3/8		3300	4800	6 500
1/2		2600	3700	5 100

Note: For gas service, select a tube thickness outside of the shaded area.

Suggested Ordering Information

High-quality, fully annealed seamless or welded and drawn alloy 20 tubing, ASTM B729, B468 or equivalent. Hardness not to exceed 95 HRB. Tubing to be free of scratches, suitable for bending and flaring. O.D. tolerances not to exceed ±0.005 in (±0.13 mm).

Alloy 600 Tubing

Allowable working pressures are based on equations from ASME B31.3 and ASME B31.1 for a maximum S value of 20 000 psig (137.8 MPa).

Table 13 — Fractional

Tube O.D. (in.)	Tube Wall Thickness, in.			
	0.028	0.035	0.049	0.065
	Working Pressure, psig			
1/4	4000	5100	7500	10200
3/8		3300	4800	6500
1/2		2600	3700	5100

Note: For gas service, select a tube thickness outside of the shaded area.

Suggested Ordering Information

High-quality, fully annealed, cold drawn #1 temper alloy 600 seamless alloy tubing, ASTM B167 or equivalent. Hardness not to exceed 92 HRB or 198 HV. Tubing to be free of scratches, suitable for bending and flaring. Order to outside diameter and wall thickness only, not to inside diameter, average wall specification. O.D. tolerances not to exceed ±0.005 in (±0.13 mm).

Grade 2 Titanium Tubing

Allowable working pressures are based on equations from ASME B31.3 and a maximum S value of 16 700 psig (115.1 MPa) for ASTM B338 tubing at -20 to 100°F (-28 to 37°C). For working pressure in accordance with ASME B31.1, multiply by 0.85.

Table 15 — Fractional

Tube O.D. (in.)	Tube Wall Thickness, in.			
	0.028	0.035	0.049	0.065
	Working Pressure, psig			
1/4	3500	4500	6700	9100
3/8		2900	4200	5800
1/2		2100	3100	4200

Note: For gas service, select a tube thickness outside of the shaded area.

Suggested Ordering Information

High-quality, fully annealed seamless or welded and drawn grade 2 titanium tubing, ASTM B338 or equivalent. Tubing to be free of scratches, suitable for bending. O.D. tolerances not to exceed ±0.005 in (±0.13 mm).

Table 10 — Metric

Tube O.D. (mm)	Tube Wall Thickness, mm			
	0.8	1.0	1.2	1.5
	Working Pressure, bar			
6	310	420	520	670
8		310	390	500
10		240	300	380
12		200	240	310

Note: For gas service, select a tube thickness outside of the shaded area.

Table 12 — Metric

Tube O.D. (mm)	Tube Wall Thickness, mm			
	0.8	1.0	1.2	1.5
	Working Pressure, bar			
6	310	420	520	670
10		240	300	380
12		200	240	310

Note: For gas service, select a tube thickness outside of the shaded area.

Table 14 — Metric

Tube O.D. (mm)	Tube Wall Thickness, mm			
	0.8	1.0	1.2	1.5
	Working Pressure, bar			
6	310	420	520	670
10		240	300	380
12		200	240	310

Note: For gas service, select a tube thickness outside of the shaded area.

Table 16 — Metric

Tube O.D. (mm)	Tube Wall Thickness, mm			
	0.8	1.0	1.2	1.5
	Working Pressure, bar			
6	290	380	470	600
10		210	260	340
12		180	220	280

Note: For gas service, select a tube thickness outside of the shaded area.

SAF 2507 Super Duplex Tubing

Allowable working pressures are calculated from an S value of 38 700 psig (266.8 MPa) for ASTM A789 tubing at -20 to 100° F (-28 to 37° C), as listed in ASME B31.3.

Table 17 — Fractional

Tube O.D. (in.)	Tube Wall Thickness, in.				
	0.035	0.049	0.065	0.083	0.095
	Working Pressure, psig				
1/4	10 000	15 000			
3/8	6 500	10 100	12 700		
1/2	5 000	7 200	10 100	12 900	
5/8		5 800	7 600	10 100	
3/4		4 700	6 300	8 500	10 000

Note: For gas service, select a tube thickness outside of the shaded area.

Suggested Ordering Information

High-quality, fully annealed SAF 2507 super duplex tubing, ASTM A789 or equivalent. Hardness not to exceed 32 HRC. Tubing to be free of scratches, suitable for bending and flaring.

Alloy 825 Tubing

Allowable working pressures are calculated from an S value of 23 300 psig (160.6 MPa) for ASTM B163 and ASTM B423 seamless tubing at -20 to 100°F (-28 to 37° C), For ASTM B704, Class 1 or equivalent welded and drawn tubing, multiply working pressure by 0.85.

Table 18 — Fractional

Tube O.D. (in.)	Tube Wall Thickness, in.		
	0.035	0.049	0.065
	Working Pressure, psig		
1/4	6400	9300	11 600
3/8	4100	5900	8 200
1/2	3000	4300	5 900

Suggested Ordering Information

High-quality, fully annealed seamless alloy 825 tubing, ASTM B163, ASTM B423, or equivalent. Fully annealed welded alloy 825 tubing, ASTM B704, class 1 or equivalent. Hardness not to exceed HR15T90 or 201 HV. Tubing to be free of scratches, suitable for bending and flaring. Wall thickness tolerances not to exceed ±10%.

Table 19 — Metric

Tube O.D. (in.)	Tube Wall Thickness, mm				
	0.8	1.0	1.2	1.5	1.8
	Working Pressure, bar				
6	410	530	660		
10		300	370	480	
12		250	300	390	480

Alloy 625 Tubing

Allowable working pressures are calculated from an S value of 26 700 psig (184.1 MPa) for ASTM B444 Grade 2 tubing at -20 to 100°F (-28 to 37° C) in accordance with ASME BPV 2001, tubing outside diameter and wall thickness tolerances from ASTM B444 for small-diameter tube.

Table 20 — Fractional

Tube O.D. (in.)	Tube Wall Thickness, in.		
	0.035	0.049	0.065
	Working Pressure, psig		
1/4	7300	10 700	14 600
3/8	4700	6 800	9 400
1/2	3500	5 000	6 800

Table 21 — Metric

Tube O.D. (mm)	Tube Wall Thickness, mm				
	0.8	1.0	1.2	1.5	1.8
	Working Pressure, bar				
6	470	610	750		
10		350	430	550	
12		290	350	450	550

Suggested Ordering Information

High-quality, fully annealed seamless alloy 625 tubing, ASTM B444, Grade 1 or equivalent. Hardness not to exceed 25 HRC or 266 HV. Tubing to be free of scratches, suitable for bending and flaring.

Note: For sizes not listed in the tables above, we recommend that a sample of the tubing and all pertinent information relating to system parameters be provided for evaluation before installation. Give tubing sample and system information to any of authorized XINVAL distributors to forward to the factory.

Pressure Ratings at Elevated Temperatures

Table 22 — Elevated Temperature Factors

Temperature		Tubing Materials											
°F	°C	Copper	Carbon Steel ^①	304/304L ^②	316/316L ^②	Alloy 400	Alloy 20 ^③	Alloy C-276 ^③	Alloy 600 ^③	Ti	SAF 2507	Alloy 825	Alloy 625
200	93	0.80	0.95	1.00	1.00	0.87	1.00	1.00	1.00	0.86	0.90	1.00	0.93
400	204	0.50	0.87 ^①	0.93	0.96	0.79	0.96	0.96	0.96	0.61	0.82	0.90	0.85
600	315			0.82	0.85	0.79	0.85	0.85	0.85	0.45	0.80	0.84	0.79
800	426			0.76	0.79	0.75	0.79	0.79	0.79			0.81	0.75
1000	537			0.69	0.76			0.76	0.35				0.73

① Based on 375°F (190°C) max.

② Dual-certified grades such as 304/304L and 316/316L meet the minimum chemistry and the mechanical properties of both alloy grades.

③ Based on the lower derating factor for stainless steel, in accordance with ASME B31.3.

To determine allowable working pressure at elevated temperatures, multiply allowable working pressures from Tables 1 through 21 by a factor shown in Table 22.

Example: Type 316/316L stainless steel 1/2 in. O.D. × 0.035 in. wall at 1000°F

1. The allowable working pressure at -20 to 100°F (-28 to 37°C) is 2600 psig.

2. The elevated temperature factor for 1000°F (537°C) is 0.76 (Table 22, above):

2600 psig × 0.76 = 1976 psig

The allowable working pressure for 316/316L 1/2 in. O.D. × 0.035 in. wall tubing at 1000°F (537°C) is 1976 psig.

Basic Ordering Number

Fractional Stainless Steel Seamless Tubing

Tube O.D. (in.)	Wall Thickness (in.)	Basic Ordering Number		Weight lb/ft
		316/316L	304/304L	
1/4	0.035	316L-TP-4-035-	304L-TP-4-035-	0.082
	0.049	316L-TP-4-049-	304L-TP-4-049-	0.107
3/8	0.049	316L-TP-6-049-	304L-TP-6-049-	0.173
	0.065	316L-TP-6-065-	304L-TP-6-065-	0.219
1/2	0.049	316L-TP-8-049-	304L-TP-8-049-	0.240
	0.065	316L-TP-8-065-	304L-TP-8-065-	0.307
3/4	0.065	316L-TP-12-065-	304L-TP-12-065-	0.484
1	0.083	316L-TP-16-083-	304L-TP-16-083-	0.827
1 1/2	0.134	316L-TP-24-134-	304L-TP-24-134-	1.989

Metric Stainless Steel Seamless Tubing

Tube O.D. (mm)	Wall Thickness (mm)	Basic Ordering Number		Weight Kg/m
		316/316L	304/304L	
6	1.0	316L-TP-6M-1.0-	304L-TP-6M-1.0-	0.125
8	1.0	316L-TP-8M-1.0-	304L-TP-8M-1.0-	0.175
10	1.0	316L-TP-10M-1.0-	304L-TP-10M-1.0-	0.226
	1.5	316L-TP-10M-1.5-	304L-TP-10M-1.5-	0.320
12	1.5	316L-TP-12M-1.5-	304L-TP-12M-1.5-	0.395
	2.0	316L-TP-12M-2.0-	304L-TP-12M-2.0-	0.501
14	1.5	316L-TP-14M-1.5-	304L-TP-14M-1.5-	0.470
	2.0	316L-TP-14M-2.0-	304L-TP-14M-2.0-	0.602
16	1.5	316L-TP-16M-1.5-	304L-TP-16M-1.5-	0.545
	2.0	316L-TP-16M-2.0-	304L-TP-16M-2.0-	0.702
18	1.5	316L-TP-18M-1.5-	304L-TP-18M-1.5-	0.620
	2.0	316L-TP-18M-2.0-	304L-TP-18M-2.0-	0.802
20	2.0	316L-TP-20M-2.0-	304L-TP-20M-2.0-	0.903
25	2.5	316L-TP-25M-2.5-	304L-TP-25M-2.5-	1.410
28	2.5	316L-TP-28M-2.5-	304L-TP-28M-2.5-	1.769
30	3.0	316L-TP-30M-3.0-	304L-TP-30M-3.0-	2.031
32	3.5	316L-TP-32M-3.5-	304L-TP-32M-3.5-	2.501
38	4.0	316L-TP-38M-4.0-	304L-TP-38M-4.0-	3.410

Weight unit conversion:
1 lb/ft=1.488 Kg/m 1 Kg/m=0.672 lb/ft

Ordering Number Description

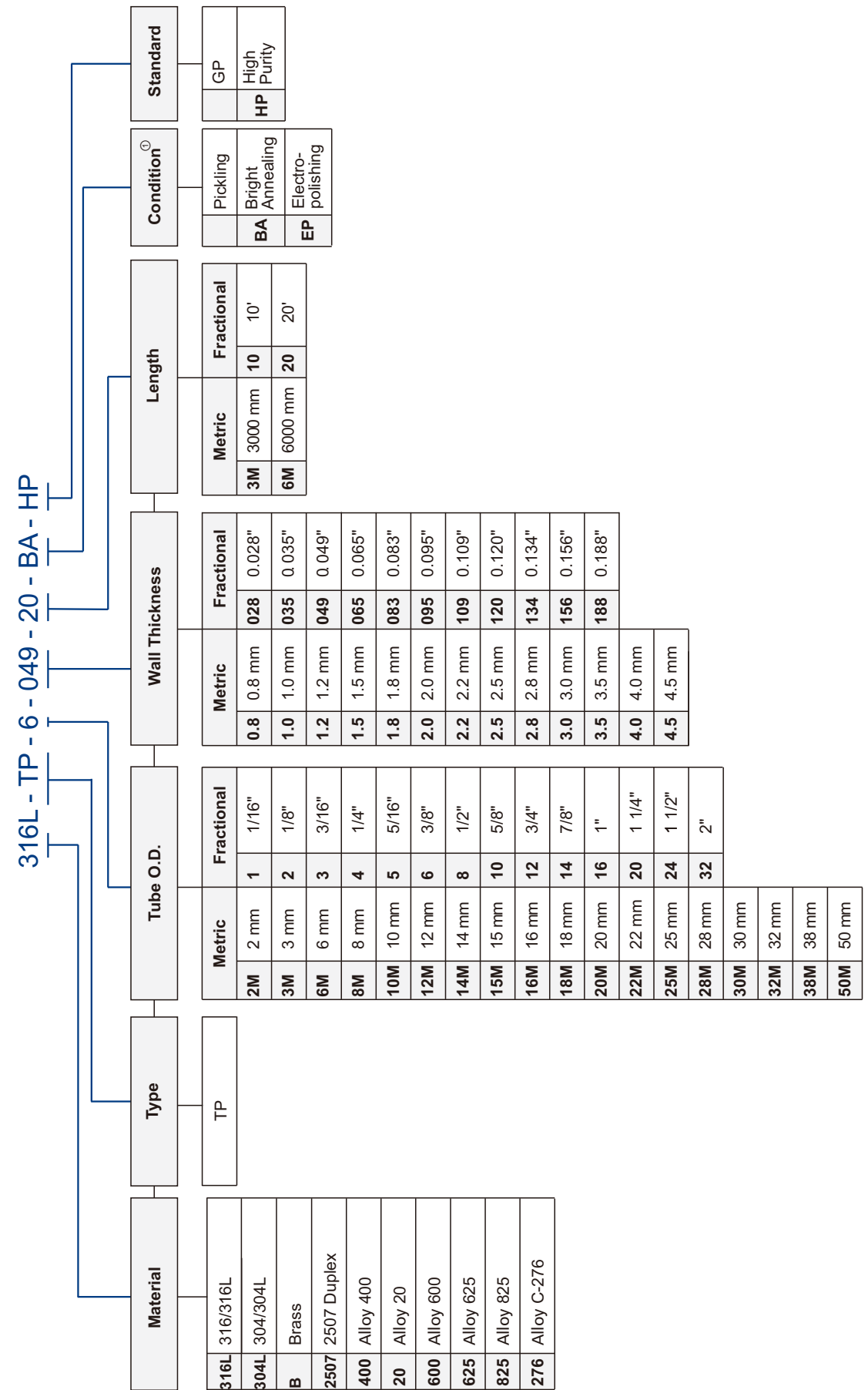

Note : " Ordering Number Description " is a reference to understand the combination rules of XINVAL product part number. Not all combinations are available.
① Applicable to 316/316L and 304/304L TP series tubing.